

TS-S2/TS-SH/TS-X/TS-P

● CE compliance

TS series are positioner type controllers that only performs point trace. No program is needed. Operation is simple. After setting point data, specify the point number and enter a START signal from host controller such as a PLC. Positioning or pushing operation then begins.



TS-S2

TS-SH

TS-X

TS-P

Main functions ▶ P.94



Handy terminal
▶ HT1/HT1-D
P.698



Support software for PC
▶ TS-Manager
P.688

■ Basic specifications

■ TS-S2/TS-SH

Item		TS-S2	TS-SH
Basic specifications	Number of controllable axes	Single-axis	
	Controllable robots	TRANSERVO series	
	Current consumption	2.5A (Rating) 4.5A (Max.)	3.5A (Rating) 6.5A (Max.)
	Dimensions	W30 × H162 × D82mm	W30 × H162 × D123mm
Weight		Approx. 0.2kg	
		Approx. 0.3kg	
Input power supply	Control power supply	DC24V +/-10%	
	Main power supply	DC24V +/-10%	
Control method		Closed loop vector control method	
Operating method		I/O point tracing (Positioning operation by specifying point number) / Remote command	
Operation types		Positioning, merge-positioning, push, and jog operations	
Axis control	Position detection method	Resolver	Resolver with multi-turn absolute function
	Resolution	20480 pulses/rev. or 4096 pulses/rev. depending on the robot	
	Origin search method	Incremental	Absolute / Incremental
Points	Points	255 points	
	Point type setting	(1) Standard setting: Set speed and acceleration in percent of the respective maximum settings. (2) Custom setting: Set speed and acceleration in SI units.	
	Point teaching method	Manual data input (coordinates input), Teaching, Direct teaching	
External input/output	I/O interface	Selectable from the following: NPN, PNP, CC-Link, DeviceNet™, EtherNet/IP™, PROFINET	
	Input	Servo ON (SERVO), reset (RESET), start (START), interlock (/LOCK) origin search (ORG), manual mode (MANUAL), jog motion - (JOG-), jog motion + (JOG+), Point number selection (PIN0 to PIN7)	
	Output	Servo status (SRV-S), alarm (/ALM), operation end (END), operation in-progress (BUSY), control outputs (OUT0 to 3), Point number output 0 to 7 (POUT0 to POUT7)	
	External communications	RS-232C 1CH	
Safety circuit		Emergency stop input, emergency stop contact output (1 system: When the HT1 is used.)	
Options	Handy terminal	HT1, HT1-D (with enable switch)	
	Support software for PC	TS-Manager	
General specifications	Operating temperature / Operating humidity	0°C to 40°C, 35% to 85%RH (non-condensing)	
	Storage temperature/ Storage humidity	-10°C to 65°C, 10% to 85%RH (non-condensing)	
	Atmosphere	Indoor location not exposed to direct sunlight. No corrosive, flammable gases, oil mist, or dust particles	
	Anti-vibration	All XYZ directions 10 to 57Hz unidirectional amplitude 0.075mm 57 to 150Hz 9.8m/s ²	
	Protective functions	Position detection error, temperature error, overload, overvoltage, low voltage, excessive position deviation, overcurrent, motor current error, motor cable faulty wiring, Excitation power failure error ^{Note 1}	

Note 1. The excitation power failure error is a protection function that is available only in TS-SH.

Controllable robot	TS-S2/TS-SH ▶ TRANSERVO P.253	TS-X ▶ FLIP-X P.295	TS-P ▶ PHASER P.341
CE marking	Field networks CC-Link DeviceNet EtherNet/IP PROFIBUS		

Model Overview

Name	TS-S2	TS-SH	TS-X/TS-P
Controllable robot	Dedicated compact single-axis TRANSERVO		TS-X: Single-axis robot FLIP-X TS-P: Linear motor single-axis PHASER
Input power	Control power supply	DC24V +/-10%	● AC100V specifications Control power supply Single phase 100 to 115V AC +/-10%
	Main power supply		● AC200V specifications Control power supply Single phase 200 to 230V AC +/-10%
Operating method	I/O point tracing / Remote command / Operation using RS-232C communication		
Maximum number of controllable axes	Single-axis		
Origin search method	Incremental	Absolute / Incremental	TS-X: Absolute / Incremental TS-P: Absolute / Semi-absolute

Ordering method

TS-S2/TS-SH (TRANSERVO)

Robot positioner	Type	I/O	Battery Note 1
S2: TS-S2 SH: TS-SH	No entry: Standard S: Sensor	NP: NPN PN: PNP CC: CC-Link DN: DeviceNet™ EP: EtherNet/IP™ PT: PROFINET GW: With no I/O board	B: With battery (Absolute model) N: None (Incremental model)

Note 1. Battery can only be selected for TS-SH. (Not provided for TS-S2).

TS-X/TS-P (FLIP-X/PHASER)

Controller	Driver: Power-supply voltage/ Power capacity	Regenerative unit	LCD monitor	Input/Output Selection	Battery Note 2
TSX: TS-X TSP: TS-P	105: 100V / 100W more less 110: 100V / 200W 205: 200V / 100W more less 210: 200V / 200W 220: 200V / 400 to 600W	No entry: None R: With RGT R: With RGU-2	No entry: None L: With LCD	NP: NPN PN: PNP CC: CC-Link DN: DeviceNet™ EP: EtherNet/IP™ PT: PROFINET GW: With no I/O board	B: With battery (Absolute model) N: None (Incremental model)

Note 2. Battery can only be selected for TS-X. (Not provided for TS-P).

TS-X/TS-P

Item	TS-X / TS-P					
	100V AC input		200V AC input			
Basic specifications	Driver model	TS-X105 / TS-P105	TS-X110 / TS-P110	TS-X205 / TS-P205	TS-X210 / TS-P210	TS-X220 / TS-P220
	Number of controllable axes	Single-axis				
	Controllable robots	TS-X: Single-axis robot FLIP-X series TS-P: Linear motor single-axis robot PHASER series				
	Power capacity	400VA	600VA	400VA	600VA	1400VA
	Dimensions	W58 × H162 × D131mm				W70 × H162 × D131mm
	Weight	Approx. 0.9kg				Approx. 1.1kg
	Input power supply	Control power supply		Single phase 100 to 115V AC +/-10% 50/60Hz		
		Main power supply		Single phase 100 to 115V AC +/-10% 50/60Hz		
Axis control	Control method	Closed loop vector control method				
	Operating method	I/O point tracing (Positioning operation by specifying point number) / Remote command				
	Operation types	Positioning, merge-positioning, push, and jog operations				
	Position detection method	TS-X: Resolver with multi-rotation absolute function TS-P: Magnetic type linear scale				
	Resolution	TS-X: 16384 pulses/rev. TS-P: 1μm				
	Origin search method	TS-X: Absolute / Incremental TS-P: Incremental / Semi-absolute				
Points	Number of points	255 points				
	Point type setting	(1) Standard setting: Set speed and acceleration in percent of the respective maximum settings. (2) Custom setting: Set speed and acceleration in SI units.				
	Point teaching method	Manual data input (coordinates input), Teaching, Direct teaching				
External input/output	I/O interface	Selectable from the following: NPN, PNP, CC-Link, DeviceNet™, EtherNet/IP™, PROFINET				
	Input	Servo ON (SERVO), reset (RESET), start (START), interlock (/LOCK) origin search (ORG), manual mode (MANUAL), jog motion - (JOG-), jog motion + (JOG+), Point number selection (PIN0 to PIN7)				
	Output	Servo status (SRV-S), alarm (/ALM), operation end (END), operation in-progress (BUSY), control outputs (OUT0 to 3), Point number output 0 to 7 (POUT0 to POUT7)				
	External communications	RS-232C 1CH				
	Power supply for brake	DC24V +/-10% 300mA (prepared by the customer)				
	Safety circuit	Emergency stop input, main power input ready output, emergency stop contact output (1 system: When the HT1 is used.)				
Options	Handy terminal	HT1, HT1-D (with enable switch)				
	Support software for PC	TS-Manager				
General specifications	Operating temperature / Operating humidity	0°C to 40°C, 35% to 85%RH (non-condensing)				
	Storage temperature / Storage humidity	-10°C to 65°C, 10% to 85%RH (non-condensing)				
	Atmosphere	Indoor location not exposed to direct sunlight. No corrosive, flammable gases, oil mist, or dust particles				
	Anti-vibration	All XYZ directions 10 to 57Hz unidirectional amplitude 0.075mm 57 to 150Hz 9.8m/s ²				
	Protective functions	Position detection error, power module error, temperature error, overload, overvoltage, low voltage, excessive position deviation, overcurrent, motor current error				
	Protective structure	IP20				

TS-S2/TS-SH/TS-X/TS-P

TS-X / TS-P specification selection table

Some specifications are automatically determined by the robot model.

TS-X

		T4LH/ C4LH	T5LH/ C5LH	T6L/ C6L	T9	T9H	F8/ C8	F8L/ C8L	F8LH/ C8LH	F10/ C10	F10H	F14/ C14	F14H/ C14H	GF14XL	F17/ C17	F17L/ C17L	GF17XL	F20/ C20	F20N	N15/ N15D	N18/ N18D	B10	B14	B14H	R5	R10	R20
Power supply voltage / Current sensor	TS-X	105	●	●	●		●	●	●	●		●		●								●	●	●	●	●	
		110				●					●			●													●
		205	●	●	●	●		●	●	●			●										●	●	●	●	●
		210				●					●			●													
	220										●		●	●			●	●	●	●	●					●	
Regenerative unit	No entry (None)				(1)	(2)				(1)	(2)	(1)	(2)	●	(3)		(6)	(3)	(4)			●	●			(5)	
	R (RGT)				(1)	(2)				(1)	(2)	(1)	(2)	●	(3)	●	(6)	(3)	(4)	●	●				(5)		

(1) Regenerative unit is needed if using in a perpendicular position and movement stroke is 700mm or more.

(4) Regenerative unit is needed if using at maximum speeds exceeding 1000mm per second.

(2) Regenerative unit is needed if using in a perpendicular position.

(5) Regenerative unit is needed if using at maximum speeds exceeding 1250mm per second.

(3) [The following arrangements require a regeneration unit.]

(6) Regenerative unit is needed if using at maximum speeds exceeding 750mm per second.

- Using in the upright position.
- To move at a speed exceeding 1,000 mm/sec horizontally.
- High lead (40) used horizontally.

TS-P

		MF7/7D	MF15/15D	MF20/20D	MF30/30D	MF75/75D
Power supply voltage / Current sensor	TS-P	105				
		110	●		●	
		205				
		210	●		●	
	220				●	●
Regenerative unit	No entry (None)	●	●			
	R (RGT)			●	●	
	R (RGU-2)					●

Part names

TS-S2/TS-SH

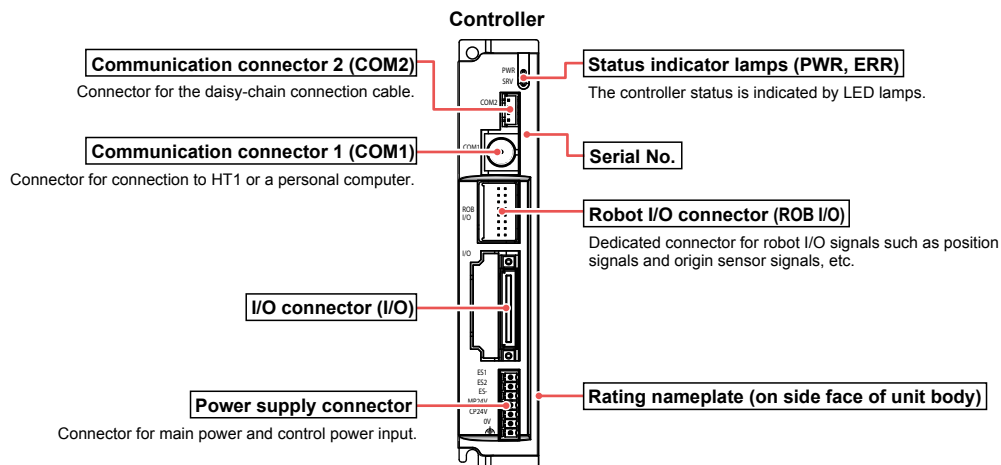

TS-X/TS-P

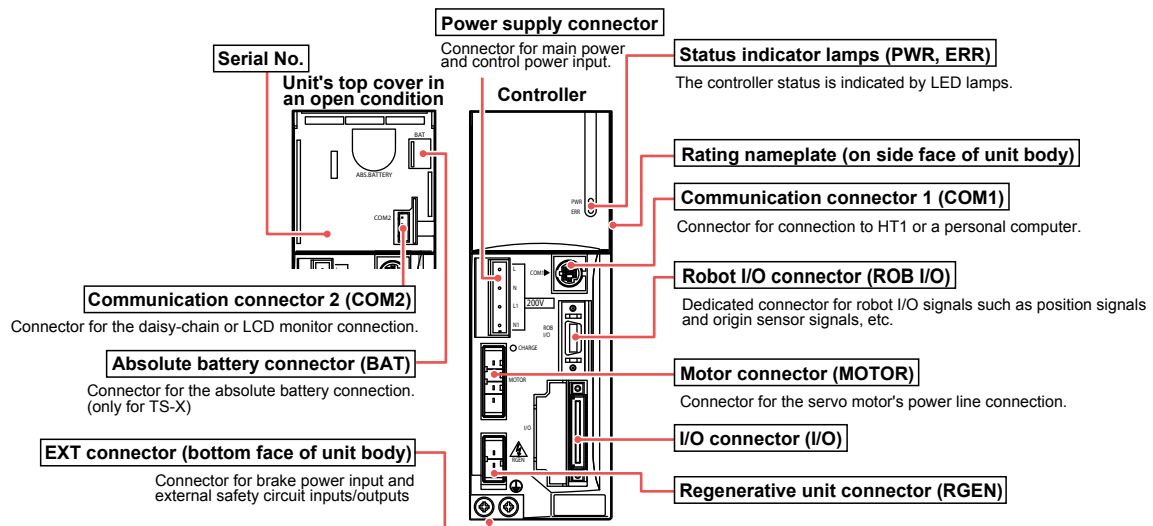

■ Dimensions

■ TS-S2

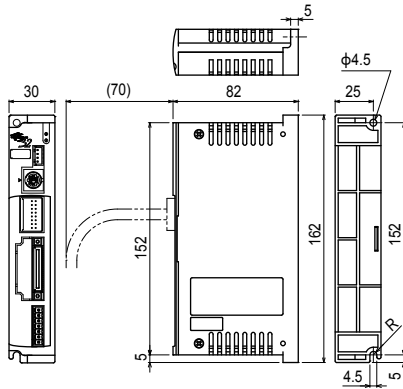

■ TS-SH

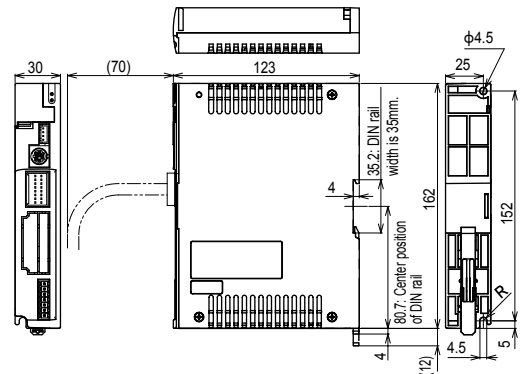

■ TS-X/TS-P (105/110/205/210)

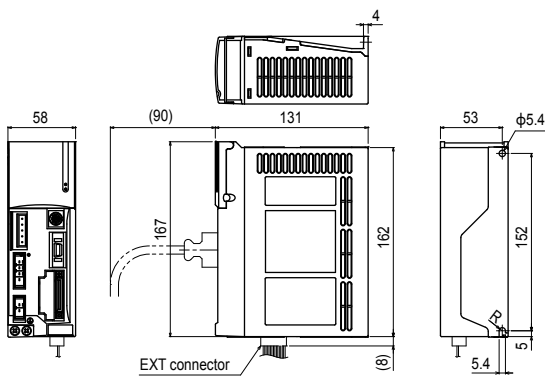

■ TS-X/TS-P (220)

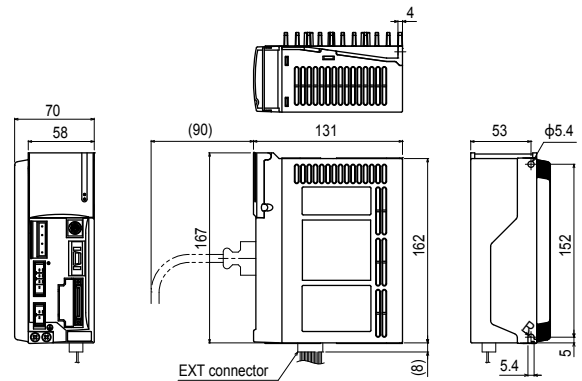

■ Installation conditions

- Install the TS-S2/TS-SH/TS-X/TS-P inside the control panel.
- Install the TS-S2/TS-SH/TS-X/TS-P on a vertical wall.
- Install the TS-S2/TS-SH/TS-X/TS-P in a well ventilated location, with space on all sides of the TS-S2/TS-SH/TS-X/TS-P (See fig. at right.).
- Ambient temperature : 0 to 40°C
- Ambient humidity : 35 to 85% RH (no condensation)

■ TS-S2/TS-SH

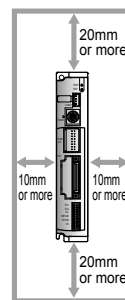

■ TS-X/TS-P

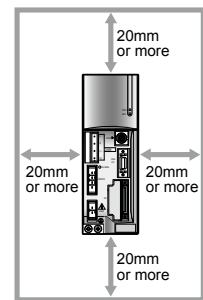

■ Cautions on TS-S2 / TS-SH

For the RF type sensor specifications, the controllers "TS-S2" and "TS-SH" become "TS-S2S" and "TS-SHS", respectively.

TS-S2 / TS-SH (Standard specifications)

"BK" label is affixed to the front of the controller.



TS-S2S / TS-SHS (Sensor specifications)

"SENSOR" label is affixed to the front of the controller.
 (Be aware that "TS-S2S" is affixed to the front of the controller.)

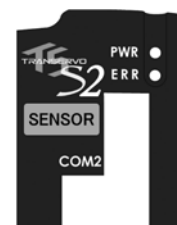

Articulated robots
YA

Linear conveyor modules
LCM

Single-axis robots
CX

Motor-less single axis actuator
Robonity

Compact single-axis robots
TRANSEVO

Single-axis robots
FLIP-X

Linear motor single-axis robots
PHASER

Cartesian robots
XY-X

SCARA robots
YK-X

Pick & place robots
YP-X

CLEAN

CONTROLLER

INFORMATION

Robot positioner

Pulse string driver

Robot controller

RCXIVY2+ Electric gripper

Option

Regenerative unit RGT/RGU-2

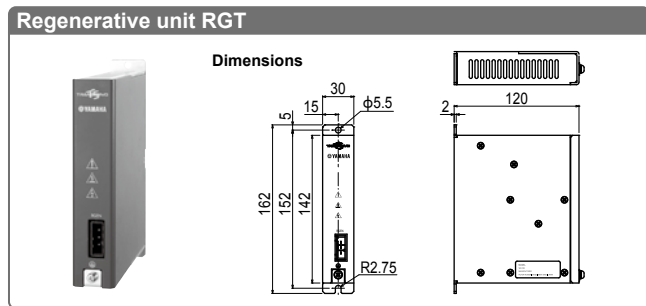

Basic specifications

Item	RGT
Model	KCA-M4107-0A (including cable supplied with unit)
Dimensions	W30 × H142 × D118mm (Not including installation stay)
Weight	470g
Regenerative voltage	Approx. 380V or more
Regenerative stop voltage	Approx. 360V or less
Accessory	Cable for connection with controller (300mm)

Note. Always leave an empty space (gap of about 20mm) between this unit and the adjacent controller.
Also, always use the dedicated cable when connecting the controller.

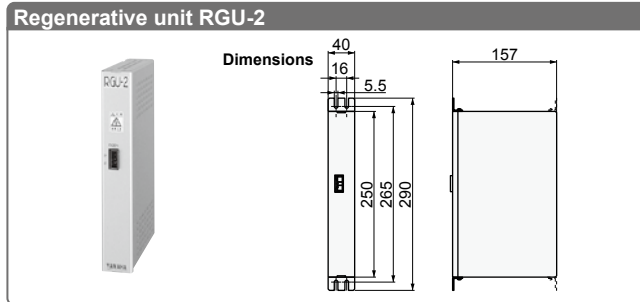

Basic specifications

Item	RGU-2 (TS-P)
Model	KCA-M4107-2A (including cable supplied with unit)
Dimensions	W40 × H250 × D157mm
Weight	0.9kg
Regenerative voltage	Approx. 380V or more
Regenerative stop voltage	Approx. 360V or less
Accessory	Cable for connection with controller (300mm)

Note. Always leave an empty space (gap of about 20mm) between this unit and the adjacent controller. Also, always use the dedicated cable when connecting the controller.

Data overview

Point data and parameter data settings must be specified in order to operate a robot from a TS series controller.

Point data

The point data used in positioning operations includes items such as the "RUN type", "Position", and "Speed", etc. Up to 255 points (P1 to P255) can be registered. There are two point data setting types: "Standard setting" type that automatically defines optimal positioning simply by specifying the payload and "Custom setting" type that allows setting the speed (mm/s) and acceleration (m/s²) in SI units. Select the desired setting type according to the application.

Parameter data

Parameter data is divided into the following categories: "RUN parameters", "I/O parameters", "option parameters", and "servo parameters".

Data structure

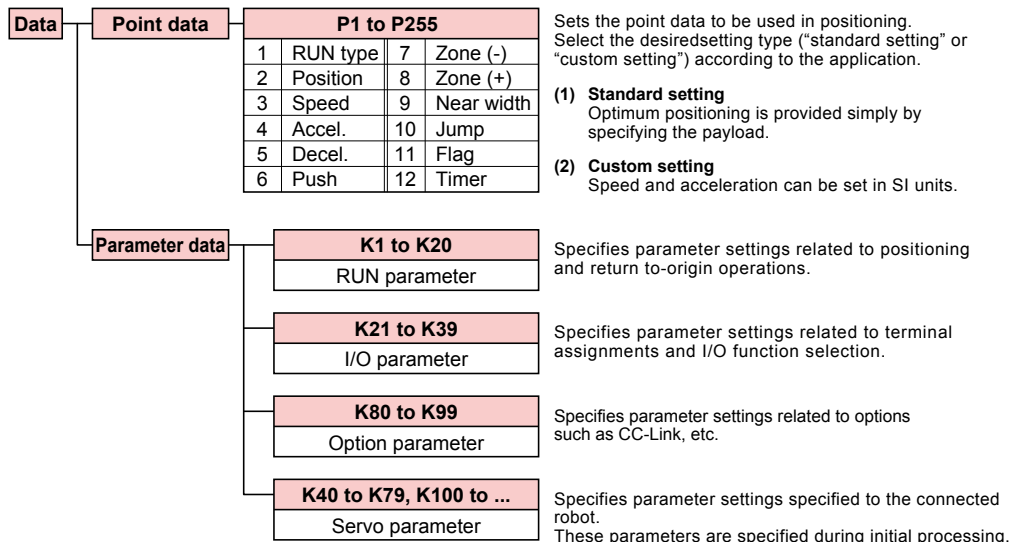

Point data

Point data item list

P1 to P255		
Item	Description	
1	RUN type	Specifies the positioning operation pattern.
2	Position	Specifies the positioning target position or movement amount.
3	Speed	Specifies the positioning speed.
4	Accel.	Specifies the positioning acceleration.
5	Decel.	Specifies the positioning deceleration (as a percentage of the acceleration).
6	Push	Specifies the electrical current limit value for "Push" operations.
7	Zone (-)	Specifies the "personal zone" output range.
8	Zone (+)	
9	Near width	Specifies the "near width" zone (distance tolerance relative to target position).
10	Jump	Specifies the next movement destination, or the next merge operation merge destination point No. following positioning completion.
11	Flag	Specifies other information related to the positioning operation.
12	Timer	Specifies the waiting time (delay) after positioning completion.

"Standard setting" and "custom setting"

There are 2 setting types for point data ("standard setting" or "custom setting"). Select the desired setting type according to the application.

The maximum number of setting points for both setting types is 255 points (P1 to P255).

Setting Type	Description
Standard setting	Optimum positioning is provided simply by specifying the payload. This setting type is well-suited to assembly and transport applications.
Custom setting	Allows changing the speed and acceleration in SI units so the desired positioning operation can be set. This setting type is suited for machining and inspection systems.

NPN type input / output wiring diagram

TS-S2/TS-SH

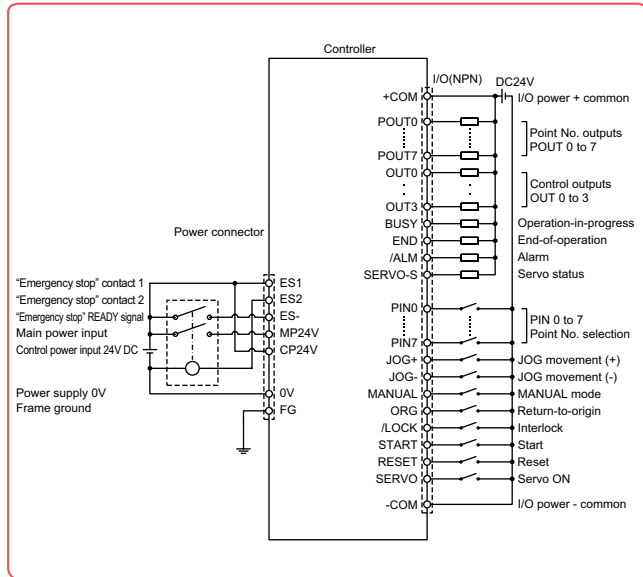

Emergency stop circuit example

TS-S2/TS-SH (power connector and host unit connection example)

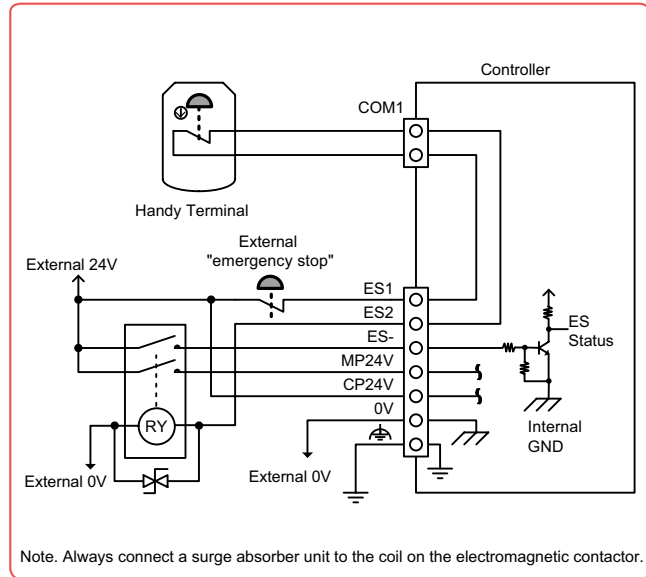

Note. Always connect a surge absorber unit to the coil on the electromagnetic contactor.

TS-X

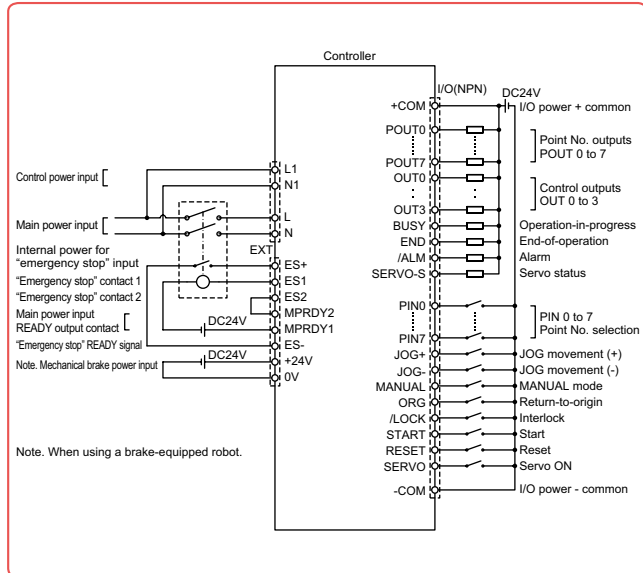

Note. When using a brake-equipped robot.

TS-X/TS-P (EXT connector and host unit connection example)

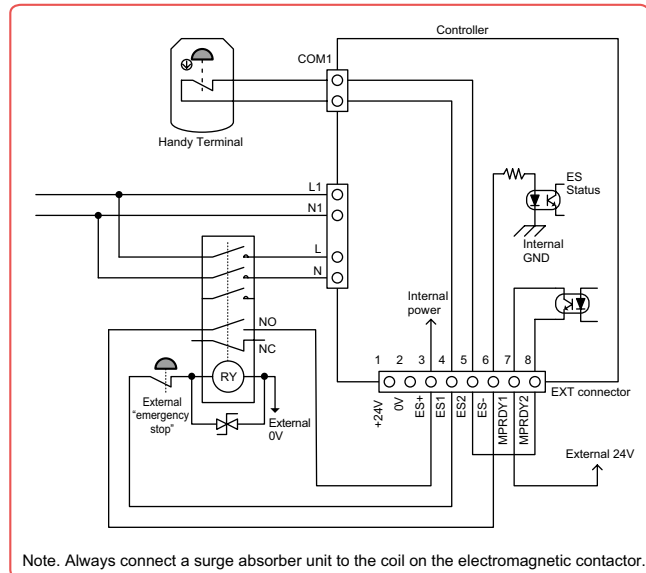

Note. Always connect a surge absorber unit to the coil on the electromagnetic contactor.

TS-P

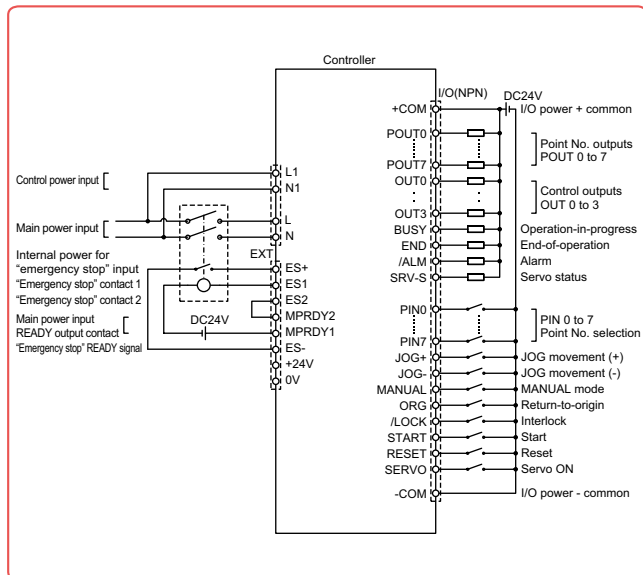

Installing an external safety circuit will satisfy safety category class 4 standards. See P.748 for more information.

I/O Specifications

Item	Description
NPN	Input 16 points, 24VDC +/-10%, 5.1mA/point, positive common Output 16 points, 24VDC +/-10%, 50mA/point, sink type
PNP	Input 16 points, 24VDC +/-10%, 5.5mA/point, minus common Output 16 points, 24VDC +/-10%, 50mA/point, source type
CC-Link	CC-Link Ver.1.10 compatible, Remote station device (1 node)
DeviceNet™	DeviceNet™ Slave 1 node
EtherNet/IP™	EtherNet/IP™ adapter (2 ports)
PROFINET	PROFINET Slave 1 node

Articulated robots YA
 Linear conveyor modules LCM
 Single-axis robots CX
 Motor-less single axis actuator Robomity
 Compact single-axis robots TRANSERO
 Single-axis robots FLIP-X
 Linear motor single-axis robots PHASER
 Cartesian robots XY-X
 SCARA robots YK-X
 Pick & place robots YP-X
 CLEAN CONTROLLER
 INFORMATION
 Robot positioner
 Pulse string driver
 Robot controller
 RCXVY2+ Electric gripper
 Option

I/O signals (NPN / PNP)

No.	Signal Name	Description	No.	Signal Name	Description	
A1	+COM	I/O power input, positive common (24VDC +/-10%)	B1	POUT0	Point No. outputs	
A2			B2	POUT1		
A3	NC	No connection	B3	POUT2		
A4			B4	POUT3		
A5	PIN0	Point No. select	B5	POUT4		
A6	PIN1		B6	POUT5		
A7	PIN2		B7	POUT6		
A8	PIN3		B8	POUT7		
A9	PIN4		B9	OUT0		
A10	PIN5		B10	OUT1		
A11	PIN6		B11	OUT2		
A12	PIN7		B12	OUT3		
A13	JOG+		JOG movement (+ direction)	B13	BUSY	Operation-in-progress
A14	JOG-		JOG movement (- direction)	B14	END	Operation-end
A15	MANUAL	MANUAL mode	B15	/ALM	Alarm	
A16	ORG	Return-to-origin	B16	SRV-S	Servo status	
A17	/LOCK	Interlock	B17	NC	No connection	
A18	START	Start	B18	NC		
A19	RESET	Reset	B19	-COM	I/O power input, negative common (0V)	
A20	SERVO	Servo ON	B20			

NPN type I/O circuit details

Input circuit

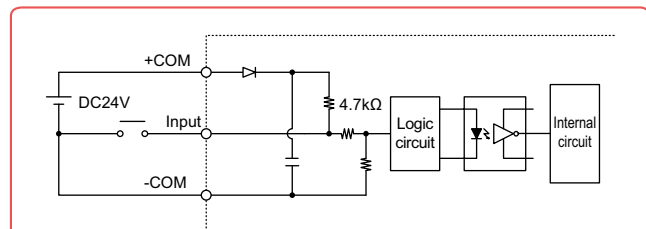

Type : DC input (plus common type)

Photo-coupler isolation format

Load : 24VDC +/- 10%, 5.1mA

OFF voltage : 19.6Vmin (1.0mA)

ON voltage : 4.9Vmax (4.0mA)

PNP type I/O circuit details

Input circuit

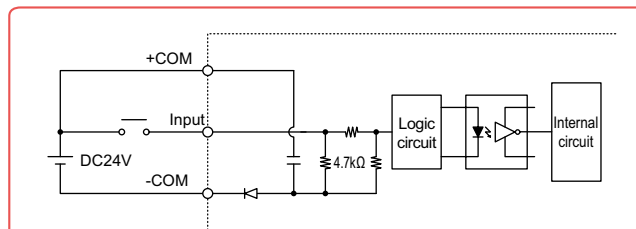

Type : DC input (minus common type)

Photo-coupler isolation format

Load : 24VDC +/- 10%, 5.5mA

ON voltage : 19.6Vmin (4.5mA)

OFF voltage : 4.9Vmax (1.1mA)

Output circuit

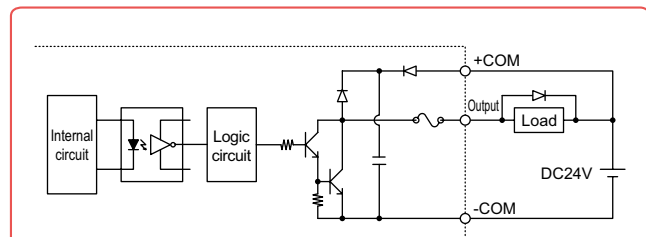

Type : NPN open collector output

(Minus common type)

Photo-coupler isolation format

Load : 24VDC, 50mA/point

Output circuit

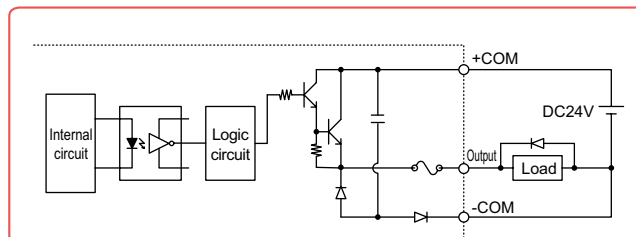

Type : PNP open collector output

(Plus common type)

Photo-coupler isolation format

Load : 24VDC, 50mA/point

Accessories and part options

TS-S2/TS-SH/TS-X/TS-P



Standard accessories

Power connector



Model KCC-M4421-00

TS-S2
TS-SH
TS-SD

Power connector (AC100V specifications)

Included when 100V model is purchased

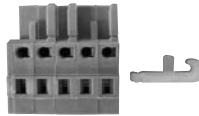

Model KCA-M5382-00

TS-X
TS-P

Power connector (AC200V specifications)

Included when 200V model is purchased

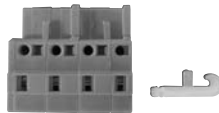

Model KAS-M5382-00

LCC140
TS-X
TS-P
SR1-X
SR1-P
RCX320
RCX221
RCX222
RCX340

EXT connector

For braking power and safety circuit connections.



Model KCA-M5370-00

TS-X
TS-P

Dummy connector



Model KCA-M5163-00

TS-S2
TS-SH
TS-X
TS-P

I/O cables (2m/20-core*2)



Model KCA-M4421-20

TS-S2
TS-SH
TS-X
TS-P

Absolute battery

Absolute battery basic specifications

Item	For TS-X	For TS-SH
Battery type	Lithium metallic battery	
Battery capacity	3.6V / 1,650mAh	3.6V / 2,700mAh
Data holding time	About 1 year (in state with no power applied)	
Dimensions	φ18 × L60mm	φ17 × L53mm
Weight	24g	21g

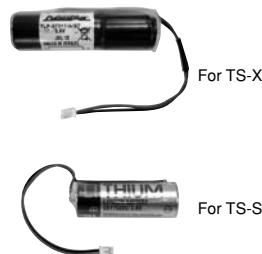

Model KCA-M53G0-10 (For TS-X)
KCA-M53G0-02 (For TS-SH)

Note. The absolute battery is subject to wear and requires replacement. If trouble occurs with the memory then remaining battery life is low so replace the absolute battery. The battery replacement period depends on usage conditions. But generally you should replace the battery after about 1 year counting the total time after connecting to the controller and left without turning on the power.

TS-X
TS-SH
RCX320
RCX340

CC-Link connector (CC-Link specifications)

Included when CC-Link model is purchased

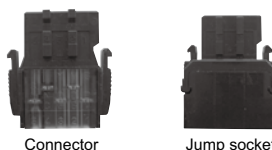

Model Connector^{Note} KCA-M4872-00
Jump socket KCA-M4873-00

Note. This is a single connector type. (Insert two connectors into a branching socket.)

TS-S2
TS-SH
TS-X
TS-P

See next page for optional parts

Articulated robots YA
Linear conveyor modules LCM
Single-axis robots CX
Motor-less single axis actuator Robotomy
Compact single-axis robots TRANSEVO
Single-axis robots FLIP-X
Linear motor single-axis robots PHASER
Cartesian robots XY-X
SCARA robots YK-X
Pick & Place robots YP-X
CLEAN
CONTROLLER INFORMATION
Robot positioner
Pulse string driver
Robot controller
RCXVY2+ Electric gripper
Option

Options

● Handy terminal HT1/HT1-D

P.698



		HT1	HT1-D
Model	3.5m	KCA-M5110-0J	KCA-M5110-1J
	10m	KCA-M5110-6J	KCA-M5110-7J
Enable switch		–	3-position
CE marking		Not supported	Applicable

TS-S2
TS-SH
TS-X
TS-P

● Support software TS-Manager

P.688



Model	KCA-M4966-0J (Japanese)
	KCA-M4966-0E (English)

TS-S2
TS-SH
TS-X
TS-P
TS-SD

● TS-Manager environment

OS	Windows 2000, XP (32bit), Vista, 7, 8 / 8.1, 10 (Supported version: V.1.4.5 or later)
CPU	Exceeding the environment recommended by the OS being used
Memory	Exceeding the environment recommended by the OS being used
Hard disk	Vacant capacity of more than 20MB in the installation destination drive
Communication port	Serial (RS-232C), USB
Applicable controllers	TS series

Note. Windows is the registered trademark of US Microsoft Corporation in U.S.A. and other countries.

● Data cables

Communication cable for TS-Manager. Select from USB cable or D-sub cable.



Model	USB type (5m)	KCA-M538F-A0
	D-Sub type (5m)	KCA-M538F-01

Note. USB driver for communication cable can also be downloaded from our website.

TS-S2
TS-SH
TS-X
TS-P
TS-SD

● Daisy chain and gateway connection cable



Model	KCA-M532L-00 (300mm)
-------	----------------------

TS-S2
TS-SH
TS-X
TS-P
TS-SD

● CC-Link termination connector (CC-Link specifications)



Model	KCA-M4874-00
-------	--------------

TS-S2
TS-SH
TS-X
TS-P

● TS-Monitor (LCD monitor) P.702



Model	For TS-X	KCA-M5119-00
	For TS-P	KCA-M5119-10

TS-X
TS-P

● DIN rail mounting bracket (This bracket is provided in TS-SH as standard equipment.)

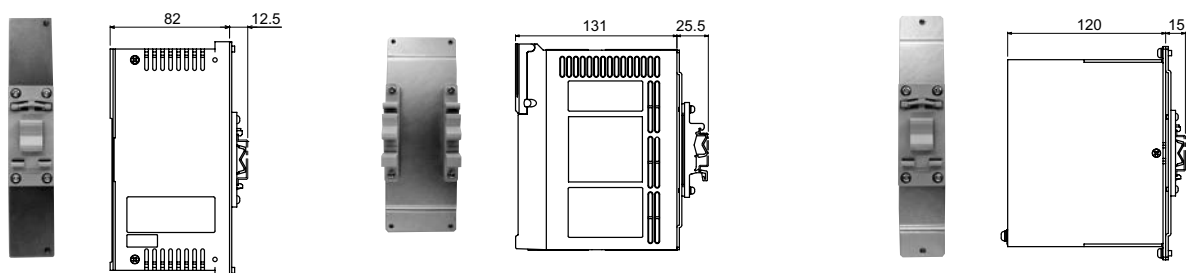

Model	For TS-S2 KCC-M499A-00
-------	---------------------------

TS-S2

Model	For TS-X / TS-P KCA-M499A-00
-------	---------------------------------

TS-X
TS-P

Model	For TS-X / TS-P with RGT KCA-M499A-10
-------	--

TS-X
TS-P